



High Speed Belt Type Digital Textile Printer

LX-1850G



280m²/h

PRODUCTION



RICOH G6 Print Head



Auto up & down motor of carriage



Large capacity two-level ink box
with electromagnetic valve



High-precision magnetic grid



Degassing module

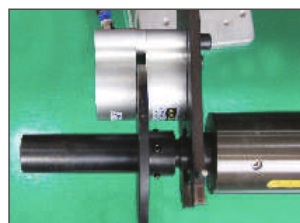

Pneumatic disc brake





LUNEX

TECHNICAL SPECIFICATIONS

MODEL	LX-1850G			
Print Head	Ricoh G6			
Number of Print Heads	4			8
Nozzle Amount	1280 Nozzles			
Effective Print Width	1800 mm			
Color	4 Colors	8 Colors	4 Colors	8 Colors
SPEED				
508x600 dpi 2 pass	140m ² h	70m ² h	280m ² h	140m ² h
508*900 dpi 3 pass	90m ² h	50m ² h	180m ² h	90m ² h
Ink Type	Reactive, Disperse, Pigment, Acid Ink			
Ink Supply Model	Auto Ink Supply of Peristaltic Pump			
Drying Type	Suspended Drying		Independent Drying Unit	
Maximum Drying Power	5 KW		20 KW	
Unwinding Device	Inflatable Shaft			
Winding Device	Inflatable Shaft Constant Tension Motor			
Carriage Adjustable Height	3 - 30 mm Adjustable			
Print Head Height	3 - 5 mm Adjustable			
Print Medium	Fabric			
Transfer Medium	Conveyor Belt			
Transmission Model	USB 3.0			
File Format	TIFF / JPG / PDF / BMP			
RIP Software	Neostampa			

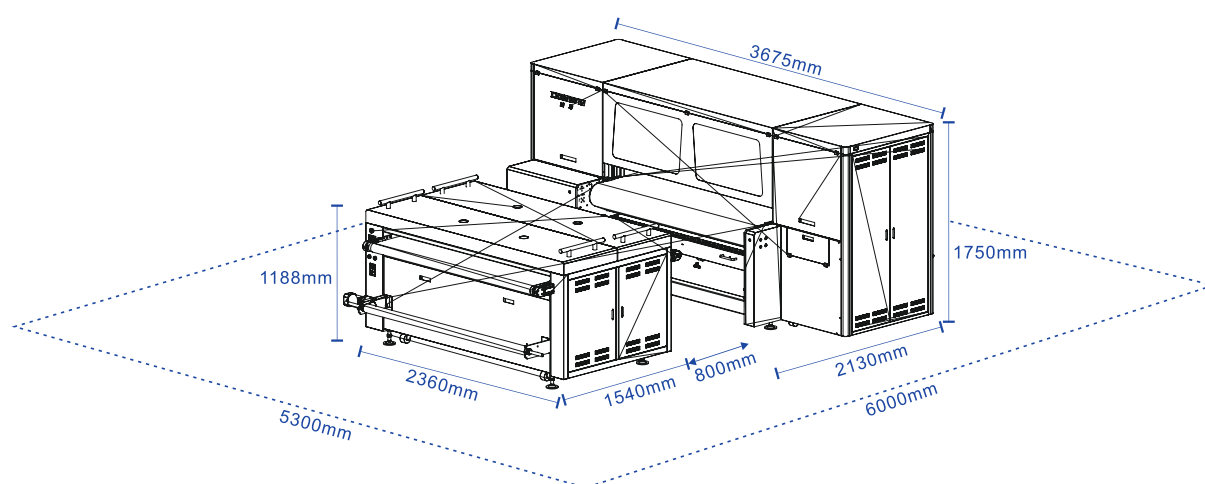

Noida Office: F-378, Sector-63, Gautam Budh Nagar
Noida, U.P.-201301. Ph: 120-4555230, 98103 03397

Gurugram Office: Shankar Chowk Road, Near Indian Overseas Bank
Vill & P.O. Dundaheera, Gurugram. Ph: 124-2438131, 95992 03397